

SOUTHEAST MACHINERY COMPANY  
114 Woodside Drive McMurray, PA 15317  
Phone: (866) 788-6910 • Fax: (724) 655-4111  
Email: [sales@southeastmachinery.com](mailto:sales@southeastmachinery.com)  
Website: [www.southeastmachinery.com](http://www.southeastmachinery.com)



## GXT Two Shaft Shredder

When continuously shredding large quantities and volumes or when pre-shredding is required for further procedures, Southeast Machinery GXT shredder with strong rotor-shearing cutting principle is the best choice. The material is sized by the hooks of the blades, pulled in and cut between the blades of the two opposed shafts. The two strong cutting rotors master all materials, even if difficult to shred or large and voluminous.



## TECHNICAL DATA GXT TWO SHAFT SHREDDERS

Model series	GXT21-40	GXT21-60	GXT21-80
A (in)	61.8	100.8	108.7
B (in)	49.6	41.7	41.7
C (in)	15.7	23.6	31.5
D (in)	18.5	18.9	18.9
H (in)	72.8	72.8	72.8
Blade Diameter (in)	11.1	11.1	11.1
Speed (rpm)	17	15	14
Blades (PCS)	20	30	40
Blade Thickness (in)	0.8	0.8	0.8
Motor Power (hp)	10	7.5+7.5	10+10
Weight (lb)	3300	5280	5720

Subject to technical changes without notice

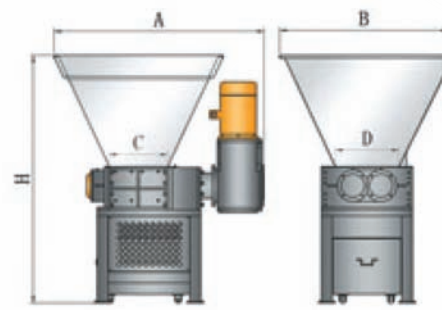

GXT21-40

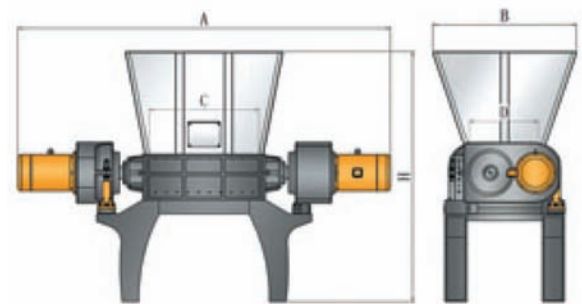

GXT21-60 & GXT21-80

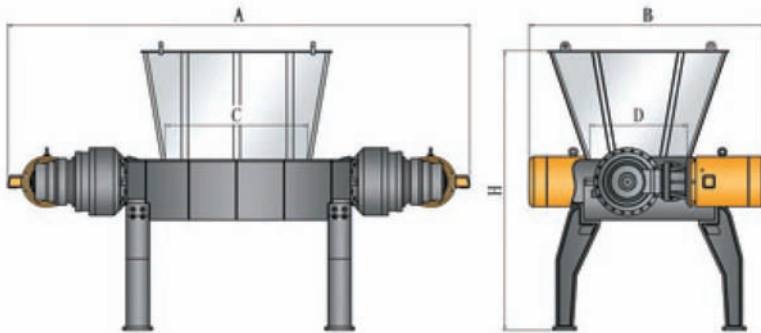

Model series	GXT32-80	GXT32-100	GXT32-120	GXT40-130	GXT40-160
A (in)	98.4	106.3	114.2	152.8	164.6
B (in)	65	68.9	72.8	78.7	84.6
C (in)	31.5	39.4	47.2	51.2	63
D (in)	27.2	27.2	27.2	33.5	3.5
H (in)	83.3	83.3	83.3	100	100
Blade Diameter (in)	17	17	17	20.2	20.2
Speed (rpm)	15	15	15	14	11
Blades (PCS)	20	25	25	32	32
Blade Thickness (in)	1.6	1.6	1.6	1.6	2
Motor Power (hp)	20+20	30+30	30+30	50+50	60 + 60
Weight (lb)	10340	12760	16060	28600	33000

Subject to technical changes without notice